

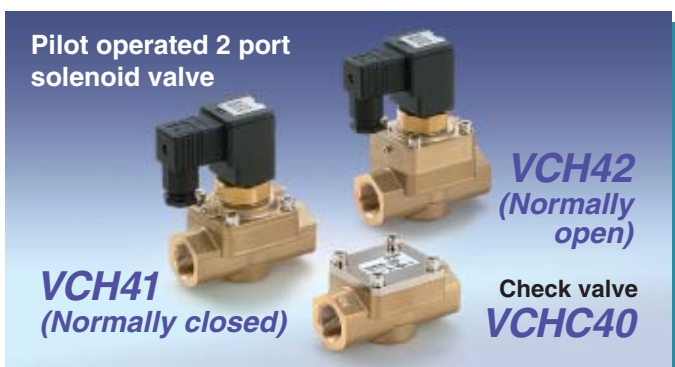

5.0 MPa Pneumatic Equipment Series

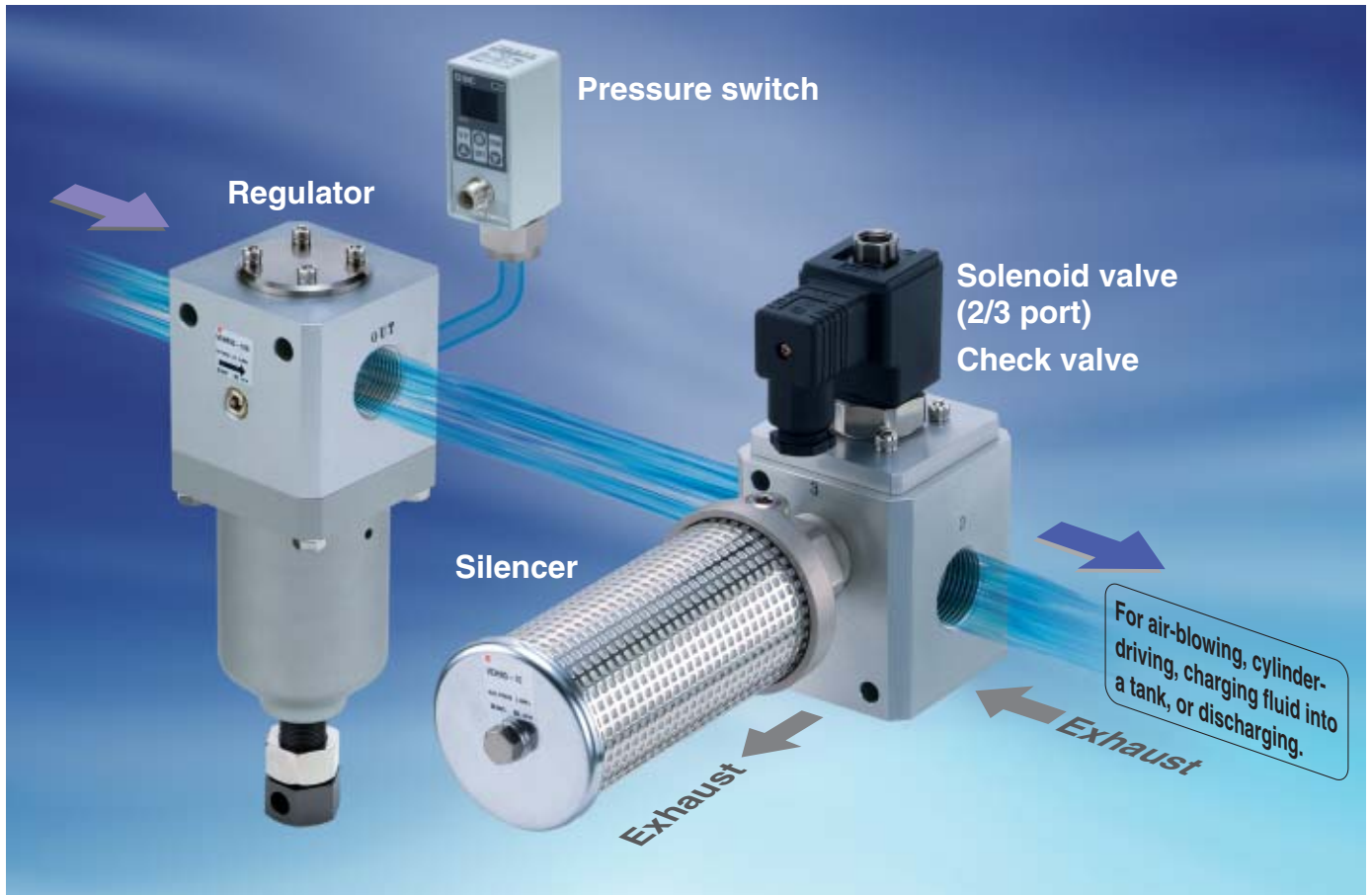

5.0 MPa

Pneumatic

Applications included air-blowing, charging fluid into a vessel, or discharging (Blow-molding equipment, etc.)

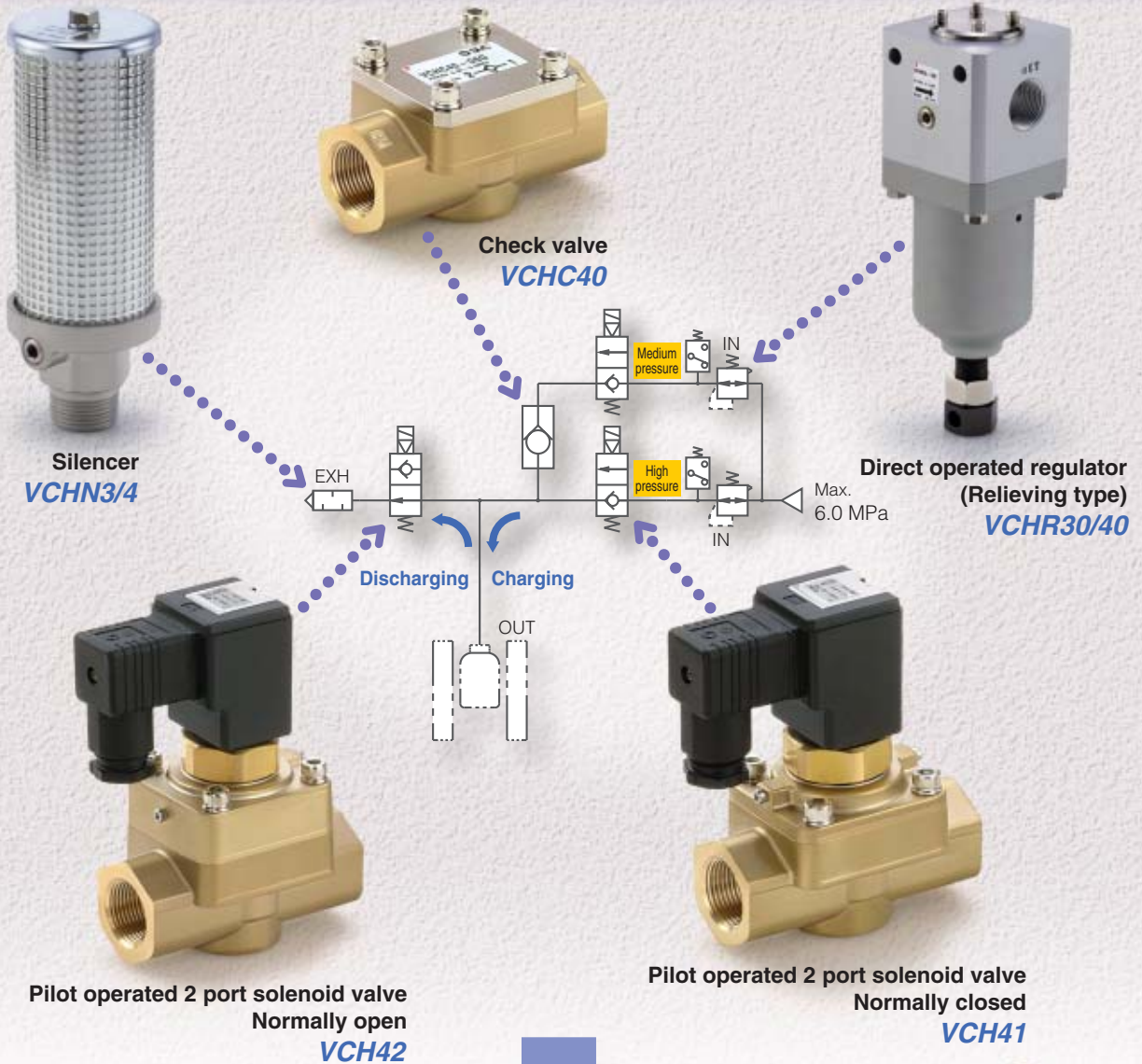

Made to Order/Manifold Unit

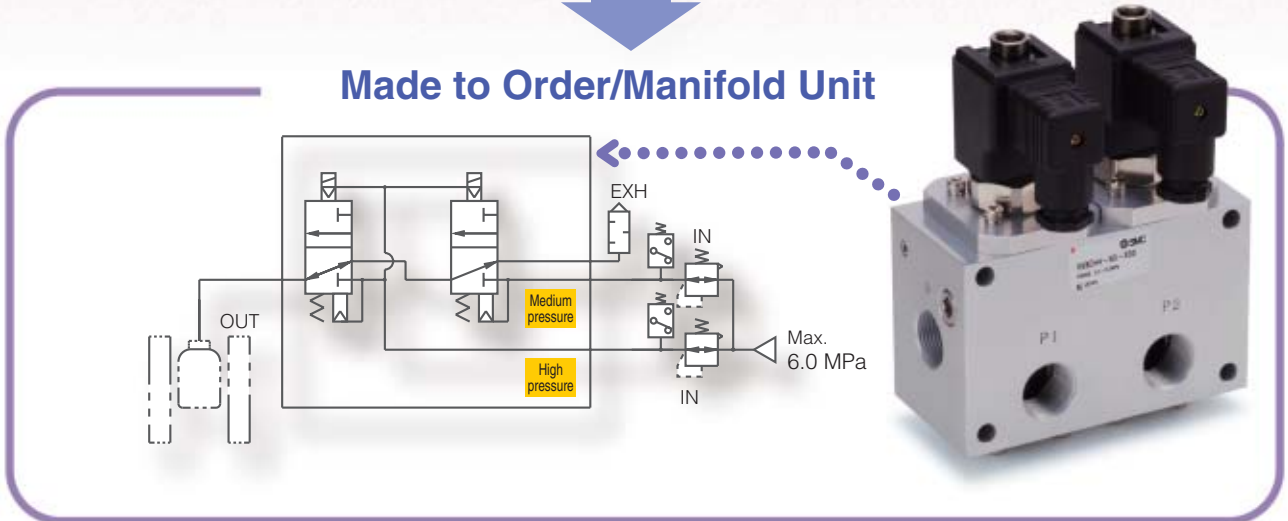

Equipment Variation

Example of driving a cylinder

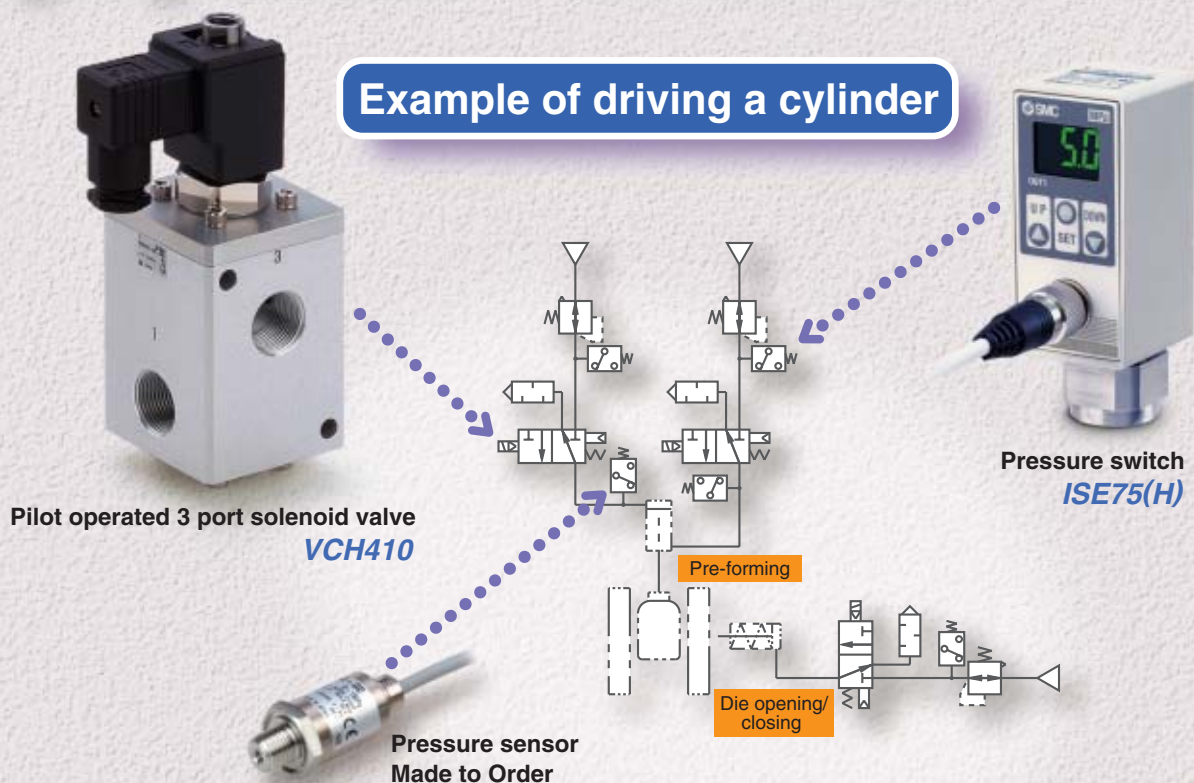

	Description	Features	Maximum operating pressure (MPa)	Series	Port size						Page	
					1/4	1/2	3/4	1	1 1/4	1 1/2		
	Pilot operated 2 port solenoid valve	Service life: 10 million cycles Adopting a polyurethane elastomer poppet in a valve seat. Improved durability under a high pressure environment.	5.0	VCH41(N.C.)			●	●			P.1	
				VCH42(N.O.)			●	●				
	Check valve			5.0	VCHC40			●	●			P.5
	Pilot operated 3 port solenoid valve			5.0	VCH410		●	●	●			P.7
	Direct operated regulator (Relieving type)			Inlet pressure 6.0 Set pressure 0.5 to 5.0	VCHR30			●	●			P.15
					VCHR40				●		●	
	Silencer		Noise reduction 35 dB(A) (At supply pressure 4.0 MPa, back pressure 2.0 MPa) Clogging-reduction with double-layer construction	5.0 (Relief valve release pressure: 1.8 MPa)	VCHN3			●	●			P.21
					VCHN4				●	●	●	

Related Equipment

	Pressure switch	2-color display Metal body (Aluminum die-cast)	10.0 15.0	ISE75(H)	●						
--	-----------------	--	--------------	-----------------	---	--	--	--	--	--	--

Made to Order P.24

- 1** 6.0 MPa pilot operated regulator (Air operated type)
- 2** 22.0 MPa 2 port air operated valve
- 3** 5.0 MPa pressure sensor

5.0 MPa Pilot Operated 2 Port Solenoid Valve & Check Valve

Series VCH40/VCHC40

For Air

Series VCH40

Stable responsiveness

Response time dispersion within ± 2 ms

Non-corrosion construction between the iron cores keeps equipment abrasion free.

Improved responsiveness when switching off.
Reduced dispersion construction

Improved durability by applying a **special surface treatment** to the sliding parts.

Unnecessary volume inside the pilot chamber is reduced.

High speed response
Reduced dispersion

Service life: 10 million cycles

Use of **shock absorbing rubber**, resulting in protection of the pilot valve and electric parts.

Improved durability under a high pressure environment with a **polyurethane elastomer** poppet

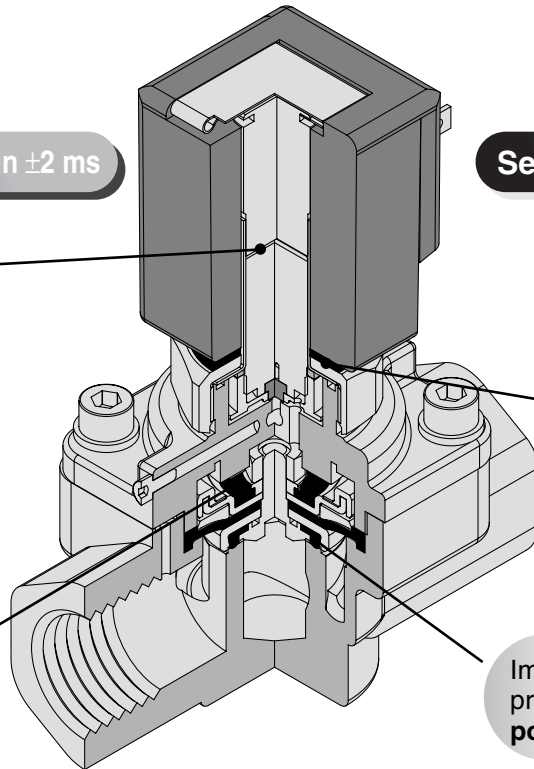

Series VCHC40

Using **NSF-H1-certified grease** on the guide ring (sliding part).

Improved durability under a high pressure environment with a **polyurethane elastomer** poppet

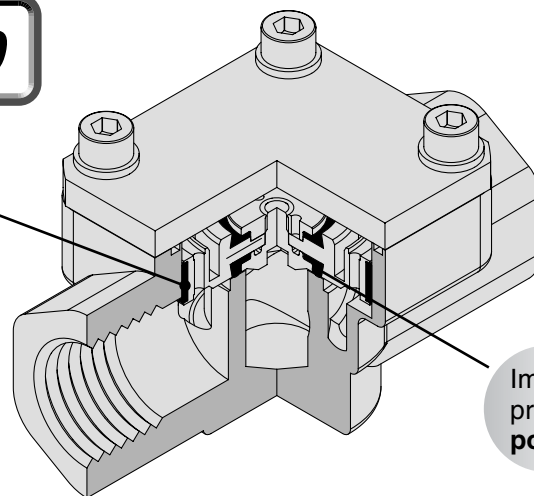

How to Order

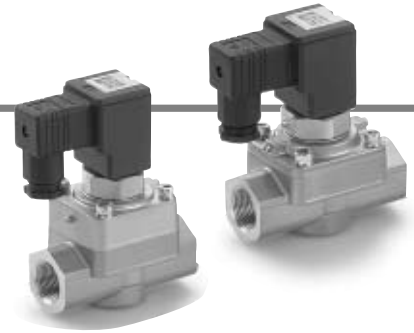

VCH4 1 - 1 D - 06 G

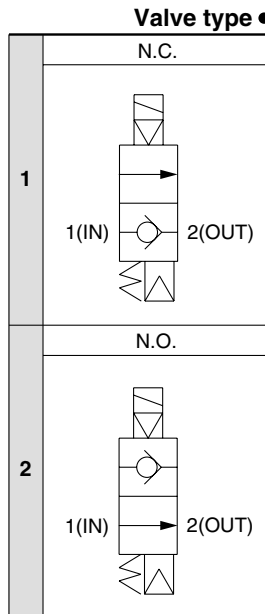

Voltage

1	100 VAC
2	200 VAC
5	24 VDC
6	12 VDC

* Consult with SMC for other voltages. CE marking compliant products are only available with 50 VDC or less.

Thread type
(Conforming to ISO1179-1 on the pneumatic/hydraulic G thread)

Port size

06	3/4
10	1

Electrical entry

D	DIN connector
DL	DIN connector with light

* A surge voltage suppressor is integrated inside the coil as a standard feature.

Specifications

Model	VCH41 (N.C.)	VCH42 (N.O.)	
Valve construction	Pilot operated, diaphragm poppet		
Fluid	Air, Insert gas		
Orifice	ø16	ø17.5	
Flow characteristics	C value (Effective area)	17 dm ³ /(s·bar) (85 mm ²)	
	b	0.08	
	Cv	4.5	
Max. operating pressure	5.0 MPa		
Operating pressure	0.5 to 5.0 MPa		
Fluid temperature	-5 to 80°C		
Ambient temperature	-5 to 80°C		
Body material	Brass		
Main seal material	Polyurethane elastomer		
Enclosure	Drip proof (Equivalent to IP65)		
Port size	G3/4, 1 (Conforming to ISO1179-1 on the pneumatic/hydraulic G thread)		
Impact/Vibration resistance <small>Note 1)</small>	300/100 m/s ² <small>Note 2)</small>		
Mounting orientation	Unrestricted		
Weight	1.67 kg	1.9 kg	
Coil specification	Rated voltage	12 VDC, 24 VDC, 100 VAC, 200 VAC (50/60 Hz)	
	Allowable voltage fluctuation	±10% of rated voltage	
	Electrical entry	DIN connector	
	Coil insulation type	Class B	
Power consumption <small>Note 3)</small>	5 W (DC), 13 VA (AC)		

Note 1) Impact resistance: No malfunction resulted in an impact test using a drop impact tester. The test was performed one time each in the axial and right angle directions of the main valve and armature, for both energized and de-energized states. (Value in the initial stage)

Vibration resistance: No malfunction resulted in 8.3 to 2000 Hz, a one-sweep test performed in the axial and right angle directions of the main valve and armature for both energized and de-energized states. (Value in the initial stage)

Note 2) Vibration resistance is 50 m/s² when a light/surge voltage suppressor is attached.

Note 3) No inrush voltages are generated in the AC solenoid because a full-wave rectifier is used.

Response Time

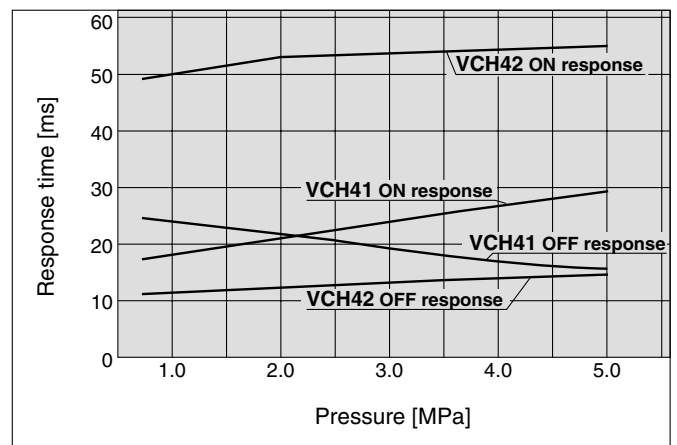

Note 1) DC solenoid without a light/surge voltage suppressor

Note 2) AC or DC solenoid with an indicator light: It will cause delays around 20 to 30 msec in the OFF response time.

Series VCH40

Construction

Normally closed (N.C.)

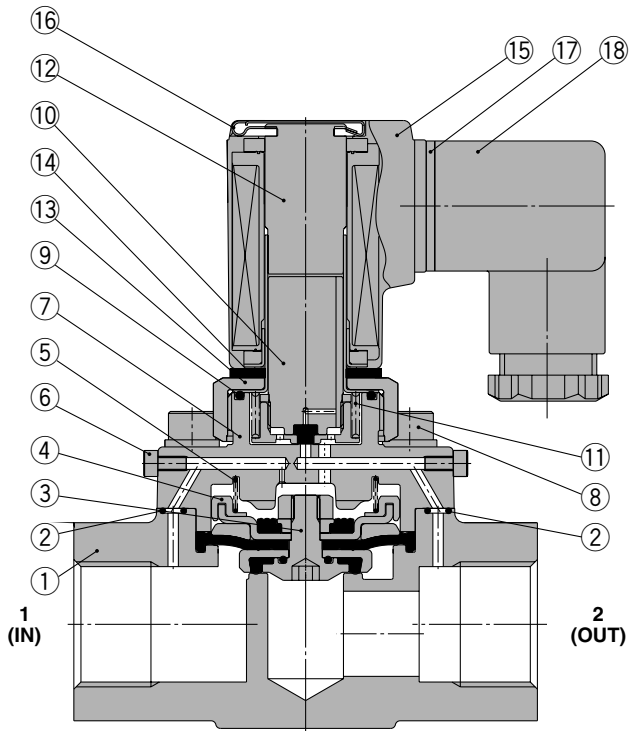

Component Parts

No.	Description	Material
1	Body	Brass
2	O-ring	NBR
3	Diaphragm assembly	Polyurethane elastomer Stainless steel
4	Main valve guide	Resin
5	Poppet spring	Stainless steel
6	Hexagon socket head cap screw	Carbon steel
7	Bonnet	Brass
8	Hexagon socket head cap screw (with SW)	Carbon steel
9	O-ring	NBR
10	Armature assembly	—
11	Return spring	Stainless steel
12	Tube assembly	Stainless steel
13	Nut	Brass
14	Rubber mount	NBR
15	DIN connector type solenoid coil	—
16	Clip	Carbon steel
17	DIN terminal gasket	CR
18	DIN connector	—

Normally open (N.O.)

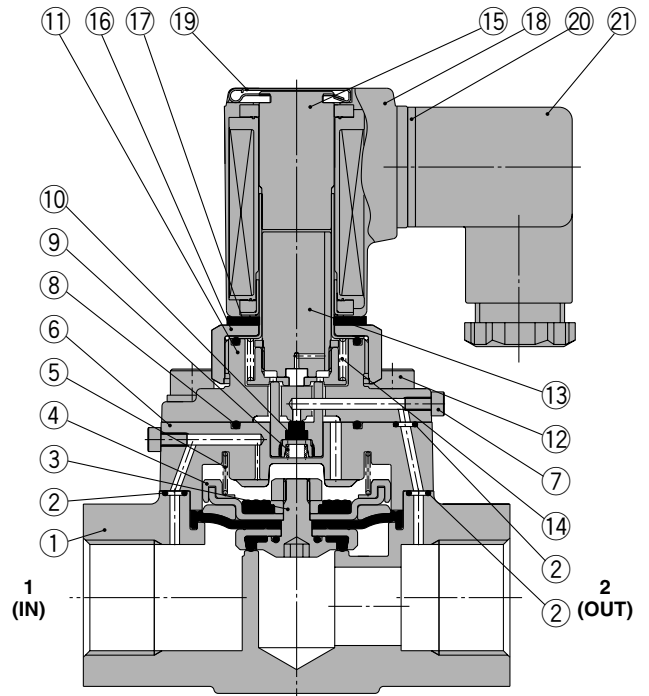

Component Parts

No.	Description	Material
1	Body	Brass
2	O-ring	NBR
3	Diaphragm assembly	Polyurethane elastomer Stainless steel
4	Main valve guide	Resin
5	Poppet spring	Stainless steel
6	Bonnet plate	Brass
7	Hexagon socket head cap screw	Carbon steel
8	O-ring	NBR
9	Valve spring	Stainless steel
10	Poppet	H-NBR
11	Bonnet	Brass
12	Hexagon socket head cap screw (with SW)	Carbon steel
13	Armature assembly	—
14	Return spring	Stainless steel
15	Tube assembly	Stainless steel
16	Nut	Brass
17	Rubber mount	NBR
18	DIN connector type solenoid coil	—
19	Clip	Carbon steel
20	DIN terminal gasket	CR
21	DIN connector	—

Dimensions

VCH41 (N.C.)

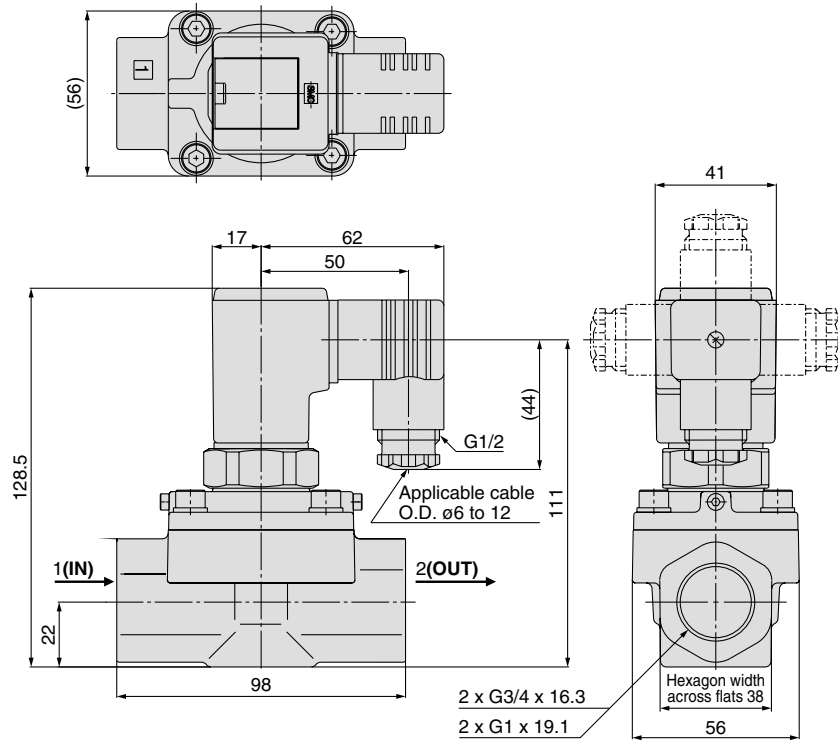

VCH42 (N.O.)

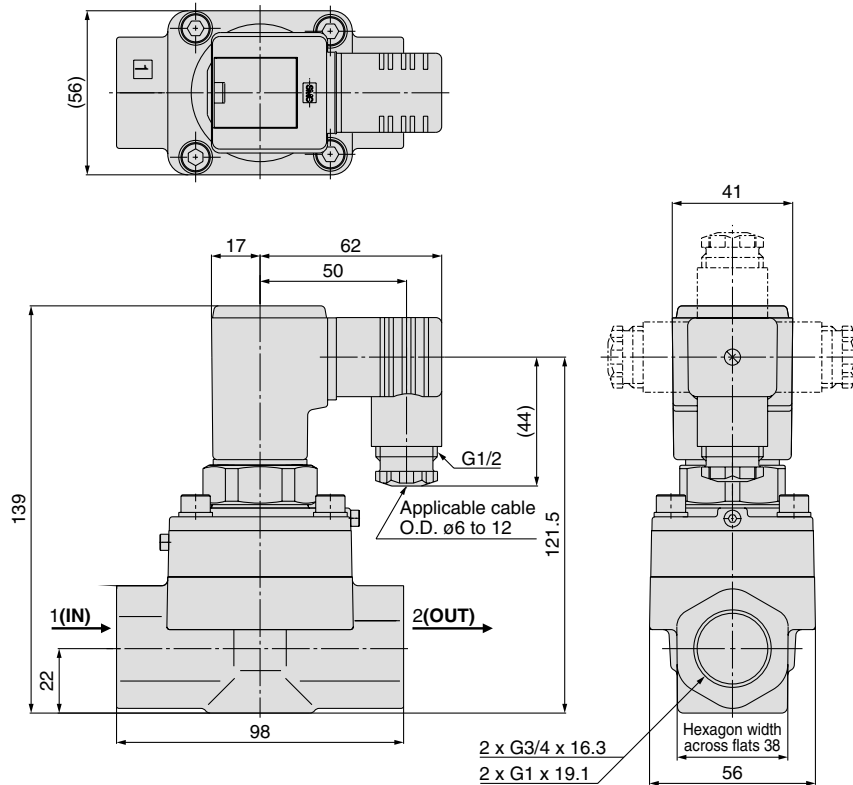

5.0 MPa Check Valve

Series *VCHC40*

How to Order



VCHC40—06 G

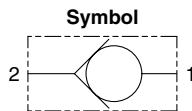

• Thread type
(Conforming to ISO1179-1 on the
pneumatic/hydraulic G thread)

• Port size

06	3/4
10	1

Specifications

Model	VCHC40	
Operating pressure	0.05 to 5.0 MPa	
Cracking pressure	0.05 MPa	
Orifice diameter	ø16	
Flow characteristics	C value (Effective area)	28 dm ³ /(s·bar) (140 mm ²)
	b	0.15
	Cv	7.4
Fluid	Air, Inert gas	
Fluid temperature	-5 to 80°C	
Ambient temperature	-5 to 80°C	
Body material	Brass	
Seal material	Polyurethane elastomer	
Port size	G3/4, 1 (Conforming to ISO1179-1 on the pneumatic/hydraulic G thread)	
Mounting orientation	Unrestricted	
Weight	1.02 kg	

Construction

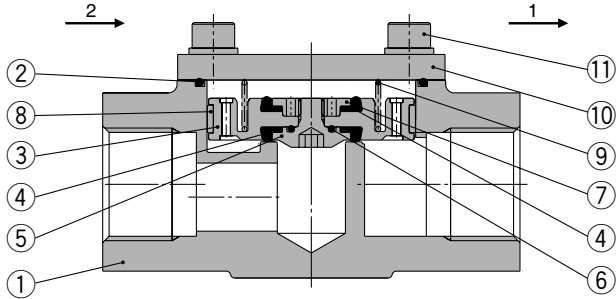

Component Parts

No.	Description	Material
1	Body	Brass
2	O-ring	NBR
3	Piston	Aluminum + Hard anodized
4	Poppet	Polyurethane elastomer
5	Set screw	Stainless steel
6	O-ring	NBR
7	Nut	Stainless steel
8	Guide ring	Resin
9	Spring	Stainless steel
10	Plate	Steel + Electroless nickel plated
11	Hexagon socket head cap screw (with SW)	Carbon steel

Dimensions

VCHC40

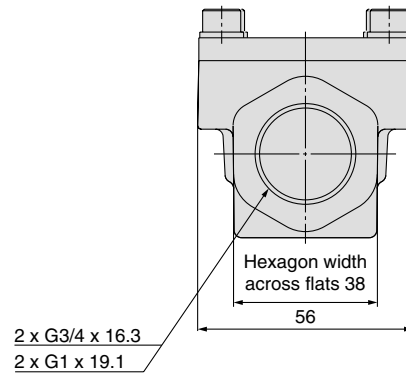
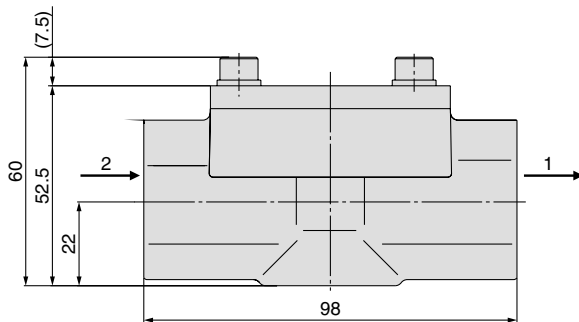
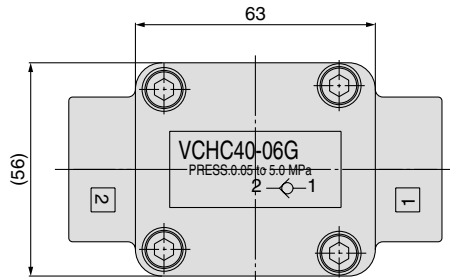

5.0 MPa Pilot Operated 3 Port Solenoid Valve

Series VCH400

For Air

Stable responsiveness

Response time dispersion within ± 2 ms

Service life: 10 million cycles

Non-corrosion construction between the iron cores keeps equipment abrasion free.



Improved responsiveness when switching off.
Reduced dispersion construction

Improved durability by applying a **special surface treatment** to the sliding parts.

Unnecessary volume inside the pilot chamber is reduced.



High speed response
Reduced dispersion

Using NSF-H1-certified grease on the guide ring (sliding part).
Special treatment containing fluoro-resin is applied to the body side sliding face.

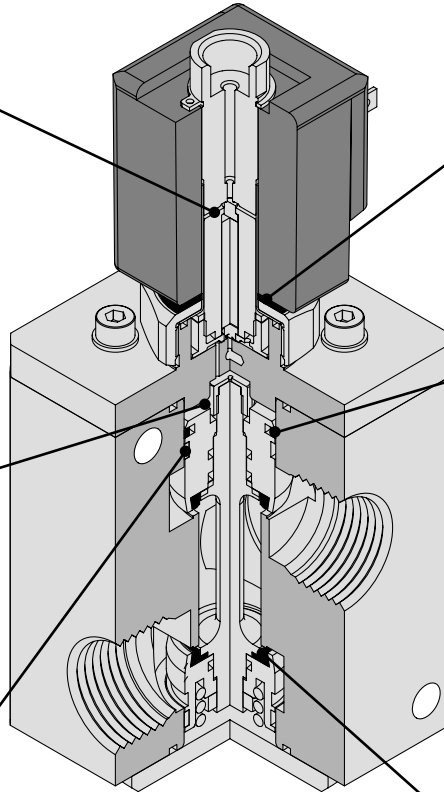

Use of **shock absorbing rubber**, resulting in protection of the pilot valve and electric parts.

Special fluoro-resin sealant is adopted for the sliding part.



Stable responsiveness after extended disuse.
No likely to subject to a pressure.

Improved durability under a high pressure environment with a **polyurethane elastomer** poppet

How to Order



VCH410-1D-06G

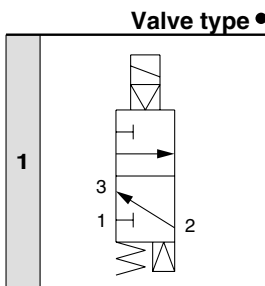

Valve type

Voltage

1	100 VAC
2	200 VAC
5	24 VDC
6	12 VDC

* Consult with SMC for other voltages.
CE marking compliant products are only available with 50 VDC or less.

Thread type
(Conforming to ISO1179-1 on the pneumatic/hydraulic G thread)

Port size

04	1/2
06	3/4
10	1

Electrical entry

D	DIN connector
DL	DIN connector with light

* A surge voltage suppressor is integrated inside the coil as a standard feature.

Specifications

Model		VCH410	
Valve construction		Pilot operated, diaphragm poppet	
Fluid		Air, Inert gas	
Orifice		ø18	
Flow characteristics	C value (Effective area)	G1/2 1→2:20 dm ³ /(s·bar) (100mm ²) 2→3:22 dm ³ /(s·bar) (110mm ²)	G3/4, 1 1→2:22 dm ³ /(s·bar) (110mm ²) 2→3:24 dm ³ /(s·bar) (120mm ²)
	b	G1/2 0.26	G3/4, 1 0.36
	Cv	G1/2 1→2 5.3 2→3 5.8	G3/4, 1 1→2 5.8 2→3 6.3
Max. operating pressure		5.0 MPa	
Operating pressure <small>Note 1)</small>		0.5 to 5.0 MPa	
Fluid temperature		-5 to 80°C	
Ambient temperature		-5 to 80°C	
Body material		Aluminum + Hard anodized	
Main seal material		Polyurethane elastomer	
Enclosure		Drip proof (Equivalent to IP65)	
Port size		G1/2, 3/4, 1 (Conforming to ISO1179-1 on the pneumatic/hydraulic G thread)	
Impact/Vibration resistance <small>Note 2)</small>		300/100 m/s ² <small>Note 3)</small>	
Mounting orientation		Unrestricted	
Weight		G1/2, 3/4: 1.83 kg, G1: 2.11 kg	
Coil specification	Rated voltage	12 VDC, 24 VDC, 100 VAC, 200 VAC (50/60 Hz)	
	Allowable voltage fluctuation	±10% of rated voltage	
	Electrical entry	DIN connector	
	Coil insulation type	Class B	
	Power consumption <small>Note 4)</small>	5 W (DC), 13 VA (AC)	

Note 1) When used as a selector valve (pressurizing 1, 3 port), the pressure in the port should be within the range of the port 1 pressure ≥ port 3 pressure x 2 (2 times).

Note 2) Impact resistance: No malfunction resulted in an impact test using a drop impact tester. The test was performed one time each in the axial and right angle directions of the main valve and armature, for both energized and de-energized states. (Value in the initial stage)

Vibration resistance: No malfunction resulted in 8.3 to 2000 Hz, a one-sweep test performed in the axial and right angle directions of the main valve and armature for both energized and de-energized states. (Value in the initial stage)

Note 3) Vibration resistance is 50 m/s² when a light/surge voltage suppressor is attached.

Note 4) No inrush voltages are generated in the AC solenoid because a full-wave rectifier is used.

Response Time

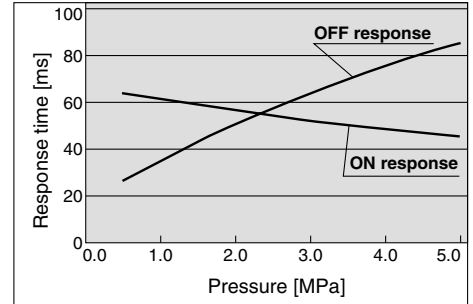

Note 1) DC solenoid without a light/surge voltage suppressor

Note 2) AC or DC solenoid with an indicator light: It will cause delays around 20 to 30 msec in the OFF response time.

Construction

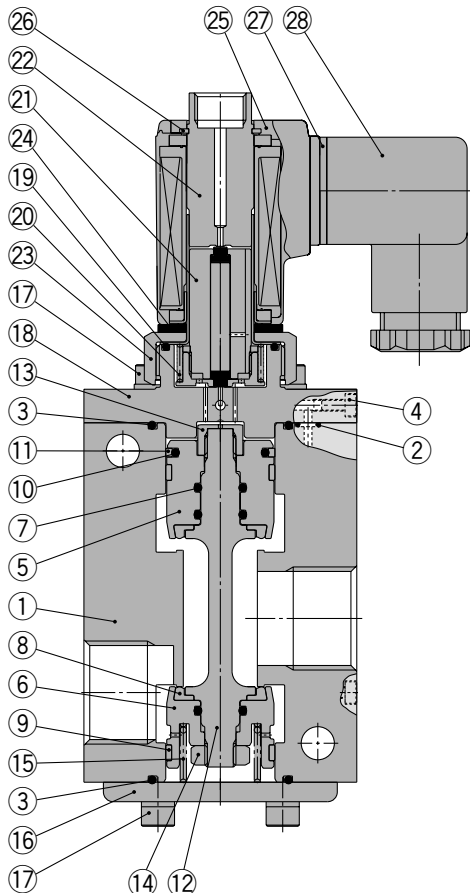

Component Parts

No.	Description	Material
1	Body	Aluminum + Hard anodized
2	O-ring	NBR
3	O-ring	NBR
4	Hexagon socket head cap screw	Carbon steel
5	Piston A	Aluminum + Hard anodized
6	Piston B	Aluminum + Hard anodized
7	O-ring	NBR
8	Poppet	Polyurethane elastomer
9	Guide ring	Resin
10	O-ring	NBR
11	Ring	Resin
12	Rod	Stainless steel
13	Hexagon nut	Brass
14	Hexagon nut class 3	Stainless steel
15	Poppet spring	Stainless steel
16	Plate	Steel + Electroless nickel plated
17	Hexagon socket head cap screw (with SW)	Carbon steel
18	Bonnet	Aluminum + Hard anodized
19	O-ring	NBR
20	Return spring	Stainless steel
21	Armature assembly	—
22	Tube assembly	Stainless steel
23	Nut	Brass
24	Rubber mount	NBR
25	DIN connector type solenoid coil	—
26	Round S-type retaining ring	Carbon steel
27	DIN terminal gasket	CR
28	DIN connector	—

Series VCH400

Dimensions

VCH410

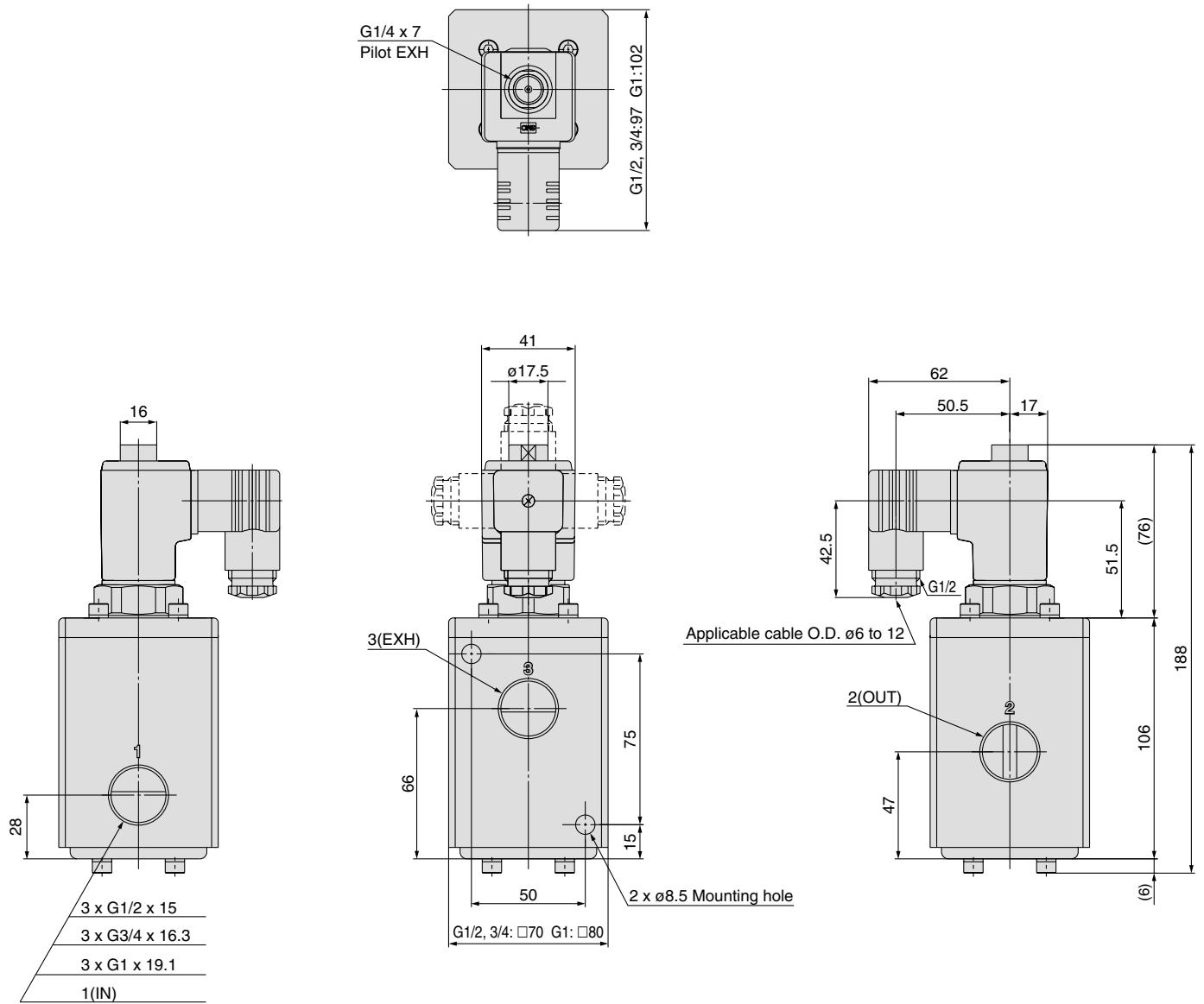





Series VCH Safety Instructions

These safety instructions are intended to prevent a hazardous situation and/or equipment damage. These instructions indicate the level of potential hazard by labels of "**Caution**", "**Warning**" or "**Danger**". To ensure safety, be sure to observe ISO 4414 ^{Note 1)}, JIS B 8370 ^{Note 2)} and other safety practices.

 **Caution:** Operator error could result in injury or equipment damage.

 **Warning:** Operator error could result in serious injury or loss of life.

 **Danger :** In extreme conditions, there is a possible result of serious injury or loss of life.

Note 1) ISO 4414: Pneumatic fluid power – General rules relating to systems

Note 2) JIS B 8370: General Rules for Pneumatic Equipment

Warning

1. The compatibility of the equipment is the responsibility of the person who designs the system or decides its specifications.

Since the products specified here are used in various operating conditions, their compatibility with a specific system must be based on specifications or post analysis and/or tests to meet your specific requirements. The expected performance and safety assurance are the responsibility of the person who has determined the compatibility of the system. This person should continuously review the suitability of all items specified, referring to the latest catalog information and taking into consideration the possibility of equipment failure when configuring a system. Be particularly careful in determining the compatibility with the fluid to be used.

2. Only trained personnel should operate machinery and equipment.

The fluid (high pressure) can be dangerous if handled incorrectly. Assembly, handling or maintenance of the system should be performed by trained and experienced operators.

3. Do not service machinery/equipment or attempt to remove components until the safety is confirmed.

1. Inspection and maintenance of machinery/equipment should only be performed once measures to prevent falling or runaway of the driven object have been confirmed. Measures to prevent danger from a fluid should also be confirmed.

2. When equipment is removed, confirm that safety processes mentioned above, release the fluid pressure and be certain there is no danger from fluid leakage or fluid remaining in the system.

3. Carefully restart the machinery, confirming that safety measures are being implemented.

4. Contact SMC if the product will be used in any of the following conditions:

1. Conditions and environments beyond the given specifications, or if product is used outdoors.

2. With fluids whose application causes concern due to the type of fluid or additives, etc.

3. An application which has the possibility of having a negative effect on people, property, or animals, requiring special safety analysis.

5. This product is not certified according to the High Pressure Gas Safety Law (in Japan).



5.0 MPa Pilot Operated 2/3 Port Solenoid Valve & Check Valve Precautions 1

Be sure to read this before handling.

Design

Warning

1. Cannot be used as an emergency shutoff valve, etc.

The valves presented in this catalog are not designed for safety applications such as an emergency shutoff valve. If the valves are used in this type of system, other reliable safety assurance measures should also be adopted.

2. Extended periods of continuous energization

The solenoid coil will generate heat when continuously energized. Avoid using in a tightly shut container. Install it in a well-ventilated area. Furthermore, do not touch it while it is being energized or right after it is energized.

3. This solenoid valve cannot be used for explosion proof applications.

4. Maintenance space

The installation should allow sufficient space for maintenance activities.

5. Actuator drive

When an actuator, such as a cylinder, is to be driven using a valve, take appropriate measures to prevent potential danger caused by actuator operation.

6. Use caution regarding exhaust port freezing.

If a high pressure air (more than 1.0 MPa) is quickly exhausted, there may be an occurrence in which the valve will not switch properly or the service life will substantially decrease due to condensation or freezing caused by the substantial temperature change. When condensation or freezing occurs, take measures such as using a freeze-reducing silencer (VCHNF series), etc.

7. Use caution regarding back pressure.

1) When port 3 (EXH) of a 3 port solenoid valve (VCH400 series) is excessively throttled or used as a selector valve (pressurizing 1, 3 port), the pressure in the port should be within a range of half the pressure in port 1 (port 1 pressure twice as strong as port 3 pressure). Using a 3 port valve beyond its back pressure and/or supply pressure range may cause the valve switch to malfunction or result in unstable operation.

2) In the case of a 3 port solenoid valve, when the valve is being switched, a high pressure air will be introduced into the lower pressure side. Therefore, when using this product as a selector valve for switching a high and medium pressure, a relief type regulator (VCHR series) must be used for the medium pressure side.

Selection

Warning

1. Confirm the specifications.

Give careful consideration to the operating conditions such as the application, fluid and environment, and use within the operating ranges specified in this catalog.

2. Fluid

Corrosive gas

Cannot be used since it will lead to cracks by stress corrosion or result in other incidents.

3. Air quality

1) Use clean air.

Do not use compressed air which includes chemicals, synthetic oils containing organic solvents, salt or corrosive gases, etc., as it can cause damage or malfunction.

2) Install air filters.

Install air filters close to valves at their upstream side. A filtration degree of 5 μm or less should be selected.

3) Install an air dryer or after-cooler, etc.

Compressed air that includes excessive drainage may cause malfunction of valves and other pneumatic equipment. To prevent this, install an air dryer or after cooler, etc.

4) If excessive carbon powder is generated, eliminate it by installing mist separators at the upstream side of valves.

If excessive carbon powder is generated by the compressor, it may adhere to the inside of the valves and cause a malfunction.

Refer to SMC's Best Pneumatics 2004 catalog Vol. 14 for further details on compressed air quality.

4. Ambient environment

Use within the operable ambient temperature range. Confirm the compatibility between the product's composition materials and the ambient atmosphere. Be sure that the fluid used does not touch the external surface of the product.

5. Supply source

If the primary side air is throttled, flow may be reduced resulting in the malfunction of the switch or instability in the response time because of the pilot operated solenoid valve. Conduct piping work suited for the secondary side piping (air consumption). Also, when a regulator is installed, the air supply will stop right after the solenoid valve is switched due to the response time of the regulator. Thus, when using it below the minimum operating pressure, adjust the pipe size, length or provide an air tank, etc.



5.0 MPa Pilot Operated 2/3 Port Solenoid Valve & Check Valve Precautions 2

Be sure to read this before handling.

Selection

⚠ Caution

1. Leakage voltage

Particularly when using a resistor in parallel with a switching element and using a C-R element (surge voltage suppressor) to protect the switching element, take note that leakage current will flow through the resistor, C-R element, etc., creating a possible danger that the valve may not turn off.

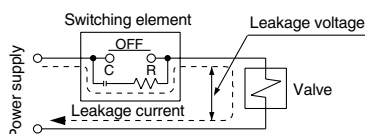

AC coil: 10% or less of rated voltage
DC coil: 2% or less of rated voltage

Mounting

⚠ Warning

1. If air leakage increases or equipment does not operate properly, stop operation.

After mounting is completed, confirm that it has been done correctly by performing a suitable function test.

2. Do not apply external force to the coil section.

Be sure to apply the wrench to the external part of the piping connection. (Hexagonal parts or width across flats) Also, use caution when mounting a silencer or piping to the VCH410 series 3 port solenoid valve because the top (G1/4) is a pilot exhaust port.

3. Be sure not to position the coil downwards.

When mounting a valve with its coil positioned downwards, foreign objects in the fluid will adhere to the iron core leading to a malfunction.

4. Avoid sources of vibration, or adjust the arm from the body to the minimum length so that resonance will not occur.

Piping

⚠ Caution

1. Preparation before piping

Before piping is connected, it should be thoroughly blown out with air (flushing) or washed to remove chips, cutting oil and other debris from inside the pipe.

Avoid pulling, compressing, or bending the valve body when piping.

2. Wrapping of pipe tape

Pipe tape is not necessary since this product uses a pneumatic and hydraulic purpose G thread which conforms to ISO 1179-1. When an R (taper) thread is used, leave 1 to 2 threads at the tip exposed before winding the piping thread around it 4 to 5 times.

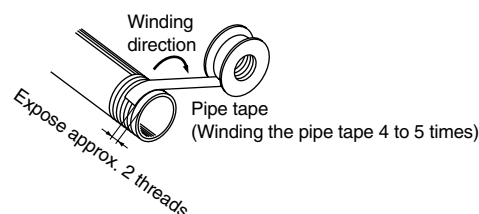

Connecting a R thread

3. Always tighten threads with the proper tightening torque.

When attaching fittings to valves, tighten with the proper tightening torque shown below.

Tightening Torque for Piping

Connection threads	Proper tightening torque N·m
G, Rc 1/2	28 to 30
G, Rc 3/4	28 to 30
G, Rc 1	36 to 38

4. Connection of piping to products

When connecting piping to a product, refer to its instruction manual to avoid mistakes regarding the supply port, etc.

- Port 1: Supply port
- Port 2: Output port
- Port 3: Exhaust port

Note) Supply port when used as a selector valve.

However, use within the range of the port 1 pressure \geq port 3 pressure x 2 (2 times).



5.0 MPa Pilot Operated 2/3 Port Solenoid Valve & Check Valve Precautions 3

Be sure to read this before handling.

Wiring

⚠ Caution

1. As a rule, use electrical wire with a cross sectional area of 0.5 to 1.25 mm² for wiring. Furthermore, do not allow excessive force to be applied to the lines.
2. Use electrical circuits which do not generate chattering in their contacts.
3. Use voltage which is within $\pm 10\%$ of the rated voltage. In cases with a DC power supply where importance is placed on responsiveness, stay within $\pm 5\%$ of the rated value. The voltage drop is the value in the lead wire section connecting the coil.
4. When a surge from the solenoid affects the electrical circuitry, install a surge absorber, etc., in parallel with the solenoid. Or, adopt an option that comes with the surge voltage protection circuit. (However, a surge voltage occurs even if the surge voltage protection circuit is used. For details, please consult with us.)

Electrical Connections

⚠ Caution

DIN connector

Since internal connections are as shown below for the DIN connector, make connections to the power supply accordingly.

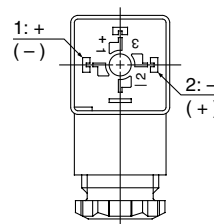

Terminal no.	1	2
DIN terminal	+ (-)	- (+)

- * There is no polarity.
- Use the compatible heavy-duty cords with cable O.D. of $\phi 6$ to 12 mm.
- Use the tightening torques below for each section.

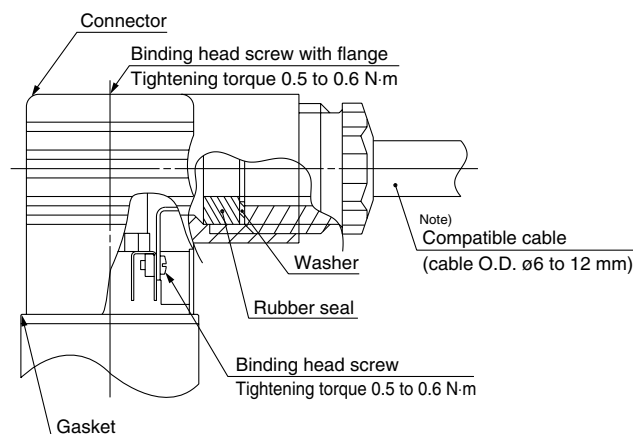

Note) For an outside cable diameter of $\phi 9$ to 12 mm, remove the internal parts of the rubber seal before using.

Electrical Circuits

⚠ Caution

DIN connector

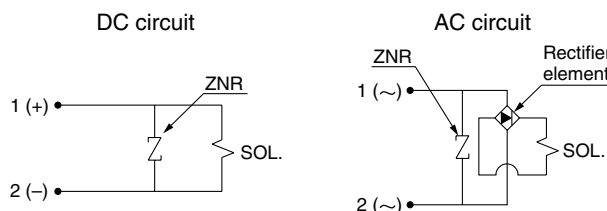



5.0 MPa Pilot Operated 2/3 Port Solenoid Valve & Check Valve Precautions 4

Be sure to read this before handling.

Operating Environment

Warning

1. Do not use the valves in an atmosphere having corrosive gases, chemicals, salt water, water, steam, or where there is direct contact with any of these.
2. Do not use in explosive atmospheres.
3. Do not use in locations subject to vibration or impact.
4. Do not use in locations where radiated heat will be received from nearby heat sources.
5. Employ suitable protective measures in locations where there is contact with water droplets, oil or welding spatter, etc.

Maintenance

Warning

1. Removing the product

1. Shut off the fluid supply and release the fluid pressure in the system.
2. Shut off the power supply.
3. Dismount the product.

2. Low frequency operation

Switch valves at least once every 30 days to prevent malfunction. Also, in order to use it under the optimum state, conduct a regular inspection once a half year.

Maintenance

Caution

1. Storage

In the case of long term storage, thoroughly remove all moisture to prevent rust and deterioration of rubber materials, etc.

2. Exhaust the drain from an air filter periodically.

6.0 MPa Direct Operated Regulator (Relieving Type)

Series *VCHR*

Service life: 10 million cycles

Using **NSF-H1-certified grease** on the guide ring (sliding) part.

Improved durability under a high pressure environment with a **polyurethane elastomer** poppet

Adopting a **metal-sealed relief valve** to improve durability.

Special fluoro-resin sealant is adopted for the sliding part.



Stable responsiveness after extended disuse.
No likely to subject to a pressure.

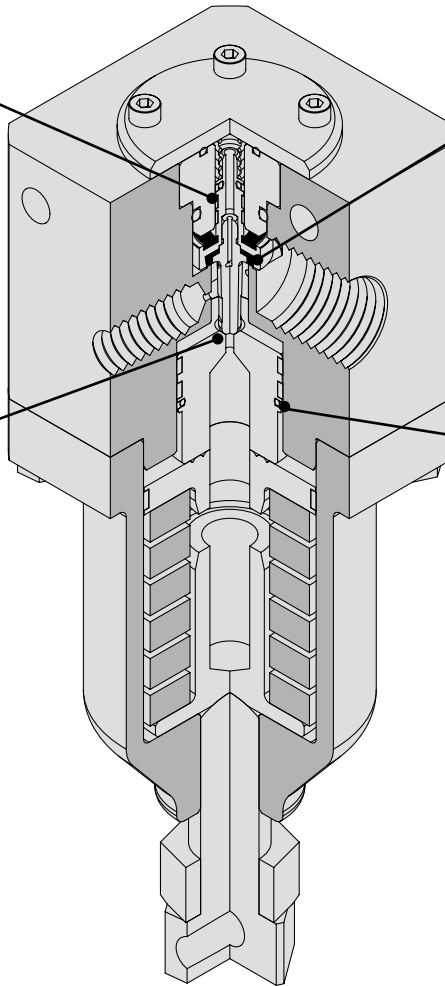

How to Order

VCHR 30-06 G

Body size

30
40

Thread type
(Conforming to ISO1179-1 on the pneumatic/hydraulic G thread)

Port size

Symbol	Port size	VCHR30	VCHR40
06	3/4	●	
10	1	●	●
14	1-1/2		●

Symbol

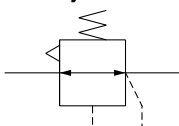

Specifications

Model	VCHR30	VCHR40
Valve construction	Piston type	
Valve material	Polyurethane elastomer	
Relief mechanism	Relieving type	
Port size	G3/4, G1	G1, G1-1/2
Thread type	Conforming to ISO1179-1 on the pneumatic/hydraulic G thread	
Fluid	Air	
Max. operating pressure	6.0 MPa	
Set pressure range	0.5 to 5.0 MPa	
Fluid temperature	-5 to 60°C	
Ambient temperature	-5 to 60°C	
Weight	4.4 kg	6.2 kg

Pressure Characteristics

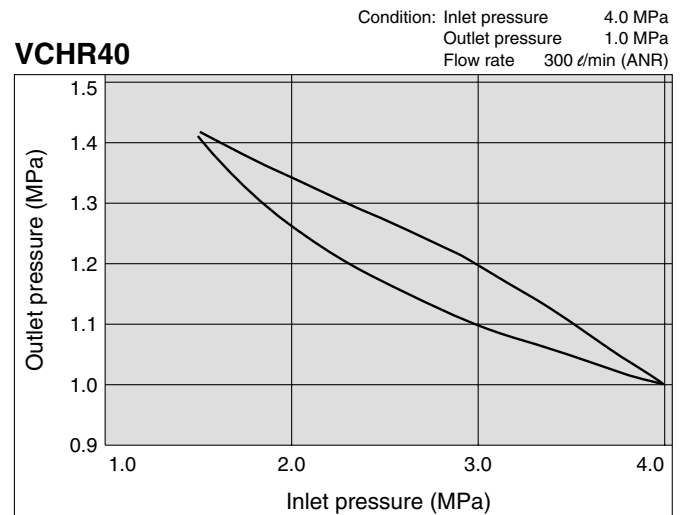
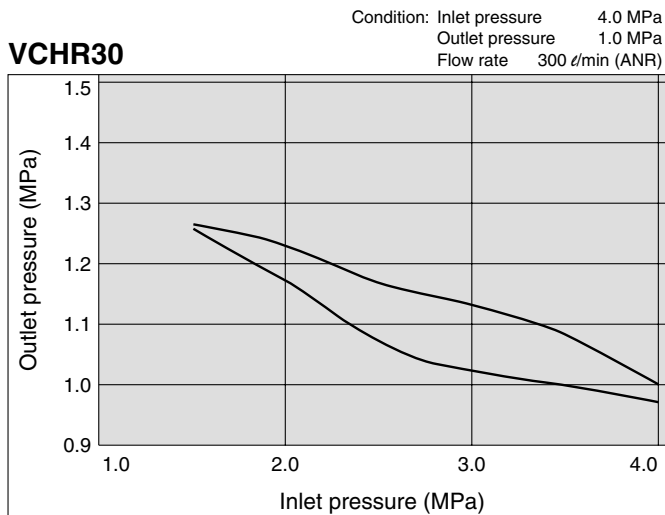

Flow Characteristics

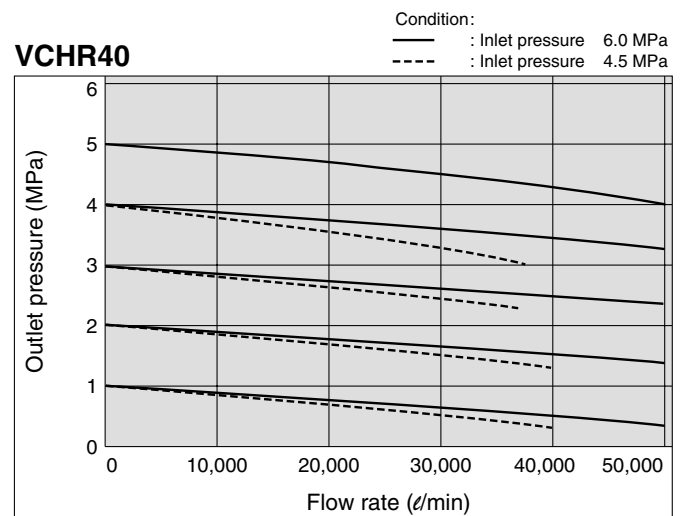
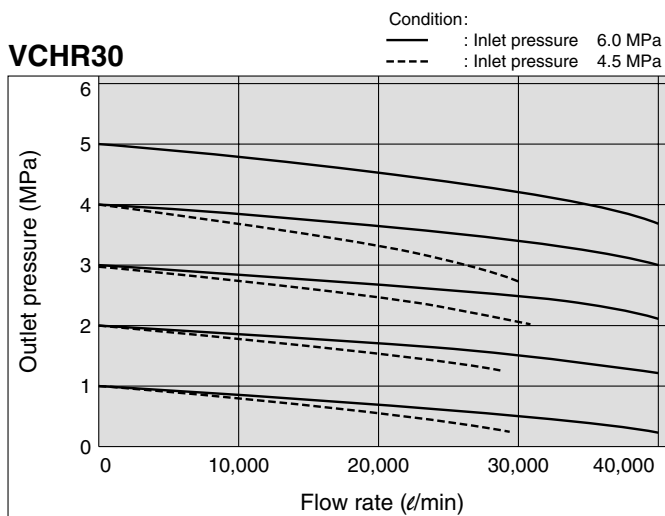

Series VCHR

Construction

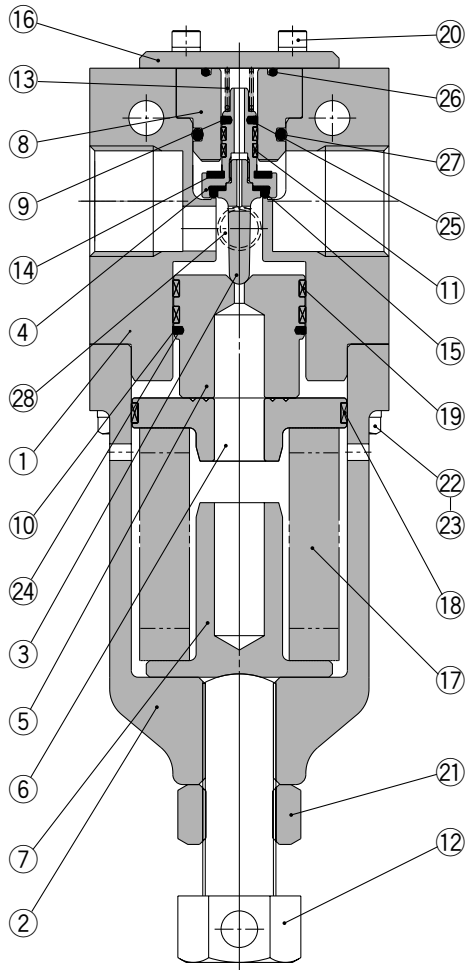

Component Parts

No.	Description	Material
1	Body	Aluminum + Hard anodized
2	Bonnet	Aluminum + Hard anodized
3	Valve	Stainless steel
4	Valve spool	Stainless steel
5	Piston	Steel + Electroless nickel plated
6	Spring guide	Steel + Electroless nickel plated
7	Spring seat	Steel + Electroless nickel plated
8	Spool guide	Aluminum + Hard anodized
9	Seal A	Resin
10	Seal B	Resin
11	Guide ring	Resin
12	Adjusting bolt	Stainless steel
13	Return spring	Stainless steel
14	Cushion	Polyurethane elastomer
15	Poppet	Polyurethane elastomer
16	Plate	Steel + Electroless nickel plated
17	Spring	Stainless steel
18	Guide ring	Resin
19	Guide ring	Resin
20	Hexagon socket head cap screw	Carbon steel
21	Hexagon nut	Carbon steel
22	Hexagon bolt	Carbon steel
23	Spring washer	Carbon steel
24	O-ring	NBR
25	O-ring	NBR
26	O-ring	NBR
27	O-ring	NBR
28	Hexagon socket head plug	Carbon steel

Dimensions

VCHR30

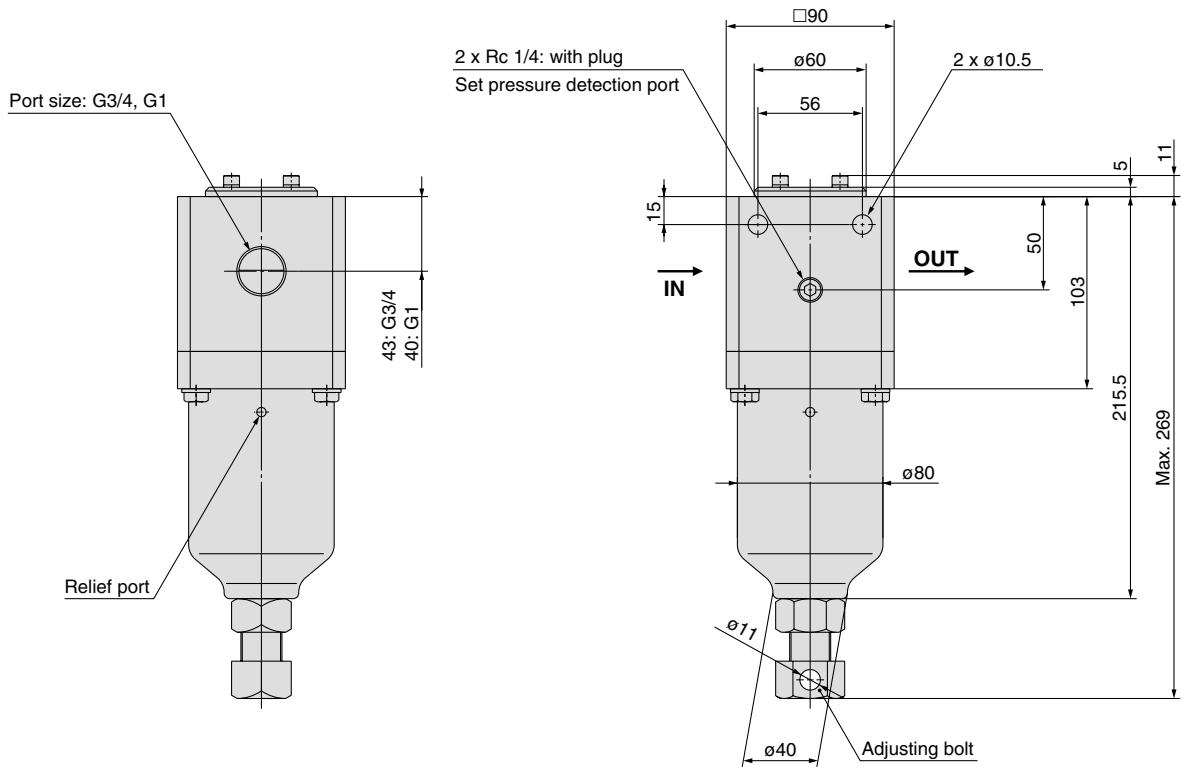

VCHR40

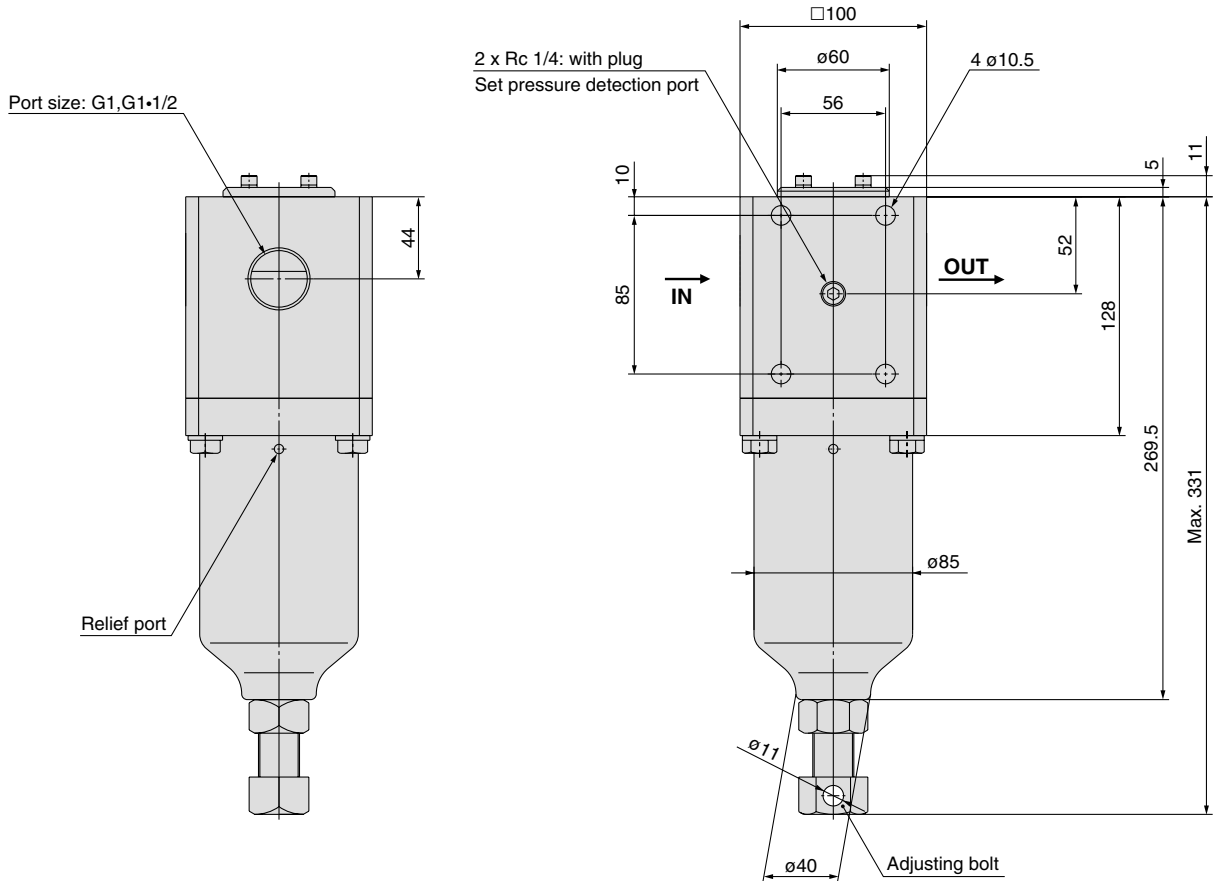



Regulator Precautions

Be sure to read this before handling.

Caution on Design

⚠ Warning

1. Consult with us when leakage is never permitted because of the operating environment, or if fluids other than air will be used.
2. Be sure to install a safety device when output pressure exceeding the set pressure value could cause equipment damage or malfunctions on the outlet side.

⚠ Caution

1. Using the product outside the specified range is not allowed. Consult with us when using the product outside the specified range of operating pressure, temperature, pressure, etc.

Selection

⚠ Warning

1. Grease may be leaking into the outlet side because it has been applied on inner sliding parts or seals. Confirm us when such cases should be avoided.
2. Contact us when the set pressure of the outlet side may fluctuate when air has not been consumed for a long period of time, or the product is used in the shut-off or balancing circuit of the outlet side.
3. The set outlet side pressure range should be less than 85% of the inlet side pressure. Setting a pressure exceeding 85% may be subject to fluctuation of flow or pressure in the inlet side, resulting in unstable operation.
4. The maximum value in catalog set pressure range has a tolerance. Therefore, the pressure setting may exceed this value.
5. Confirm with us when the product will be used in circuits, requiring highly precise relief sensitivity or setting precision.

Mounting

⚠ Caution

1. Confirm the “IN” and “OUT” showing the inlet/outlet of the air flow or arrow mark before connection. Reverse connections will result in malfunctions.
2. Provide adequate space for maintenance or operation in the upper, lower and front of each product. Regarding this space, refer to the dimensions of each product.

Adjustment

⚠ Warning

1. Adjust while confirming the pressure gauge value in the inlet and outlet sides. Overrotating the handle will damage the inner products.

⚠ Caution

1. Adjust after carefully confirming the inlet pressure.
2. Setting pressure with the handle should be conducted in the upper direction. Setting pressure in the lower direction may go below the original set pressure. Turning the handle clockwise will increase the outlet side pressure. Meanwhile, turning counterclockwise will decrease the pressure.

Piping

⚠ Warning

1. When tightening a screw on the piping material, use the recommended torque, holding the female side.
Insufficient torque will cause looseness or inferior sealing. However, overtightening will cause damage to the thread. Also, tightening without holding the female side will put excessive direct stress on brackets, etc., resulting in damage, etc.
2. Use caution so twisting or bending other than self-weight moment will not be applied to the product. Otherwise, it will result in damage. Support the external pipings separately.
3. Inflexible piping such as steel piping is subject to excessive moment load or transmission of vibrations from the piping side. Use flexible tubing, etc. between them to avoid it.



Series VCHR Specific Product Precautions

Be sure to read this before handling.

Adjustment

Caution

1. When adjusting the outlet side pressure, moment is applied on the adjusting bolt. Support it separately so that moment is not applied to the external pipings.

Reference for Handle Moment

Unit: N·m

Set pressure	1 MPa	2 MPa	3 MPa	4 MPa	5 MPa
Torque	3	6	9	12	15

2. When adjusting the outlet side pressure, the adjusting bolt (32 mm width across flats) can be fixed with a wrench. A screwdriver of approximately 20 to 30 mm can also be used for easy adjustments, using the (ø11) hole on the width across flats.

Piping

Warning

1. When tightening a screw on the piping material, use the recommended torque, holding the female side.

Insufficient torque will cause looseness or inferior sealing. However, overtightening will cause damage to the thread. Also, tightening without holding the female side will put excessive direct stress on brackets, etc., resulting in damage, etc.

Recommended Tightening Torque

Unit: N·m

Connecting thread	3/4	1	1•1/2
Torque	28 to 30	36 to 38	48 to 50

Disassembly

Caution

1. This product cannot be disassembled since it is made of precision components with a specific tolerance.

5.0 MPa Silencer Series *VCHN*

35 dB(A) noise reduction

(At supply pressure of 4.0 MPa, back pressure 2.0 MPa)

* 45 dB(A) noise reduction model can be "Made to Order".

**1/10 Clogging reduction
(SMC comparison)**

Double-layer sound absorbing material
with different filtration reduces clogging.

Standard integrated relief valve

The relief valve will activate when
the silencer's internal pressure
exceeds 1.8 MPa.

* The error indicator and the pressure switch, etc.
can be mounted as "Made to Order".

Improved maintenance

By **removing a bolt**, the sound
absorbing material can be replaced
without removing the silencer.

**30-40% reduction in freezing
(SMC comparison) (Optional)**

Freezing is reduced by a high pressure
sleeve and quick exhaust.

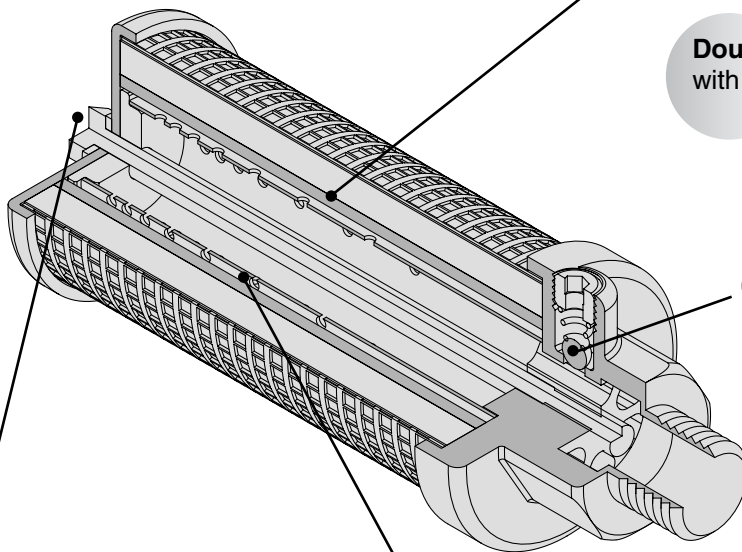

How to Order

VCHN 3 06

Option

Nil	None
F	With freeze reduction

Port size

Symbol	Port size	VCHN□3	VCHN□4
06	R3/4	●	
10	R1	●	●
12	R1-1/4		●
14	R1-1/2		●

Body size

3
4

Symbol

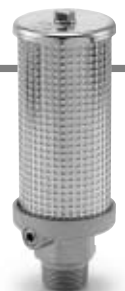
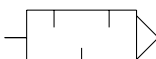

Specifications

Model	VCHN3		VCHNF3		VCHN4			VCHNF4		
Fluid	Air, Inert gas									
Max. operating pressure (MPa)	5.0 (Solenoid valve inlet pressure)									
Relief valve unlocking pressure (MPa)	1.8									
Port size	R3/4	R1	R3/4	R1	R1	R1•1/4	R1•1/2	R1	R1•1/4	R1•1/2
Effective area (mm ²)	200	280	160	180	280	370	370	180	320	320
Sound absorbing material effective area (Single) (mm ²)	420					500				
Fluid temperature (°C)	5 to 80									
Ambient temperature (°C)	5 to 80									
Noise reduction dB(A)	35 (Supply pressure 4.0 MPa, Back pressure 2.0 MPa)									

Construction/Dimensions

VCHN₄-06 to 14

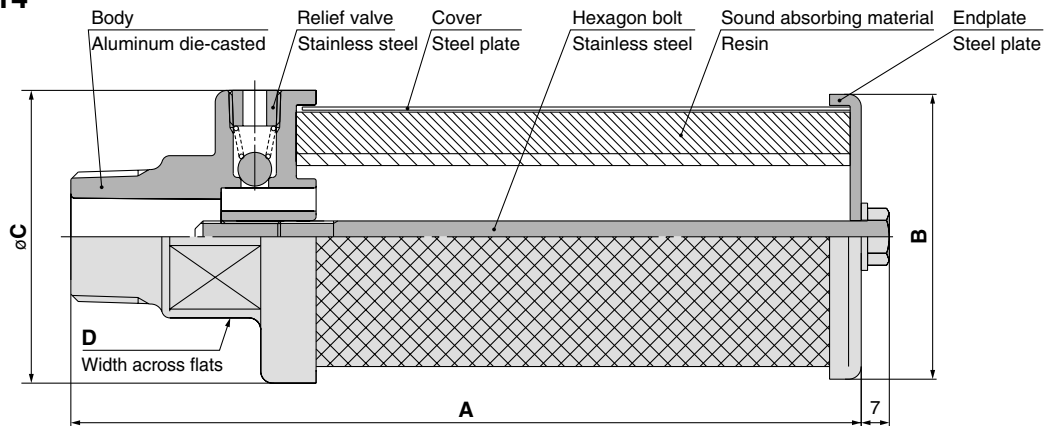

Freeze reduction type/Option

VCHNF₄-06 to 14

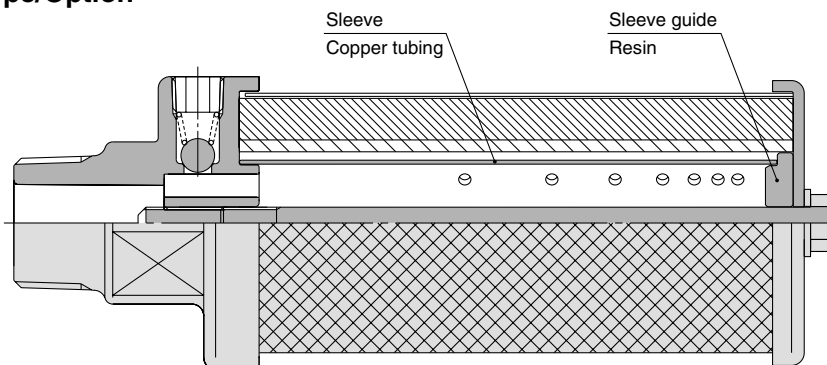

(mm)

Model	Port size (R)	A	B	C	D	Weight (g)
VCHN3-06	3/4	200	ø72	ø74	41	590
VCHNF3-06	3/4	200	ø72	ø74	41	710
VCHN3-10	1	200	ø72	ø74	41	605
VCHNF3-10	1	200	ø72	ø74	41	725
VCHN4-10	1	230	ø72	ø74	41	665
VCHNF4-10	1	230	ø72	ø74	41	810
VCHN4-12	1•1/4	240	ø72	ø74	54	765
VCHNF4-12	1•1/4	240	ø72	ø74	54	910
VCHN4-14	1•1/2	240	ø72	ø74	54	790
VCHNF4-14	1•1/2	240	ø72	ø74	54	935



Series VCHN Specific Product Precautions

Be sure to read this before handling.

Caution on Design

Warning

1. The exhaust port can clog due to a clogged or frozen silencer.

Consider design safety to avoid malfunctions of the entire system. Also, under conditions conducive to freezing, use a freeze-reduction model. (VCHNF series)

Caution

1. A silencer reduces compressed air exhaust noise from the pneumatic equipment.

Noise other than that generated by the exhaust assembly (noise generated inside piping, due to equipment vibration, solenoid valve switching, etc.) cannot be reduced. As for noise generated by sources other than the exhaust, locate the cause and take measures.

2. Silencer inlet side pressure shows the solenoid valve supply pressure (P1). (See below.)

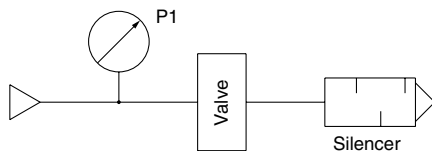

3. Noise reduction may vary, depending on the pneumatic circuit or pressure, etc. exhausted from solenoid valves.

Adjustment

Caution

1. Select a silencer with a larger effective area (including the synthetic effective area) than the solenoid valve.

Mounting

Caution

1. Tighten the silencer, using an appropriate wrench on the width across flats, within the range of the recommended tightening torque as shown below.

Do not use a pipe wrench. Otherwise, the silencer will be damaged.

Recommended Tightening Torque (Unit: N·m)

Connecting thread	3/4	1	1·1/4	1·1/2
Torque	28 to 30	36 to 38	40 to 42	48 to 50

2. Do not apply a lateral load on the main body during or after mounting.
3. When the silencer has loosened due to vibrations from the mounted equipment, mount the silencer after applying an anti-loosening agent to the thread.

Maintenance

Caution

1. When exhaust speed begins to slow from clogging and system functionality begins to degrade, replace with a new silencer or sound-absorbant material.

Also, be sure to confirm the actuator's operation status once per day.

How to Replace the Sound Absorbing Material

Caution

1. When replacing the sound absorbing material, please follow the instructions below.

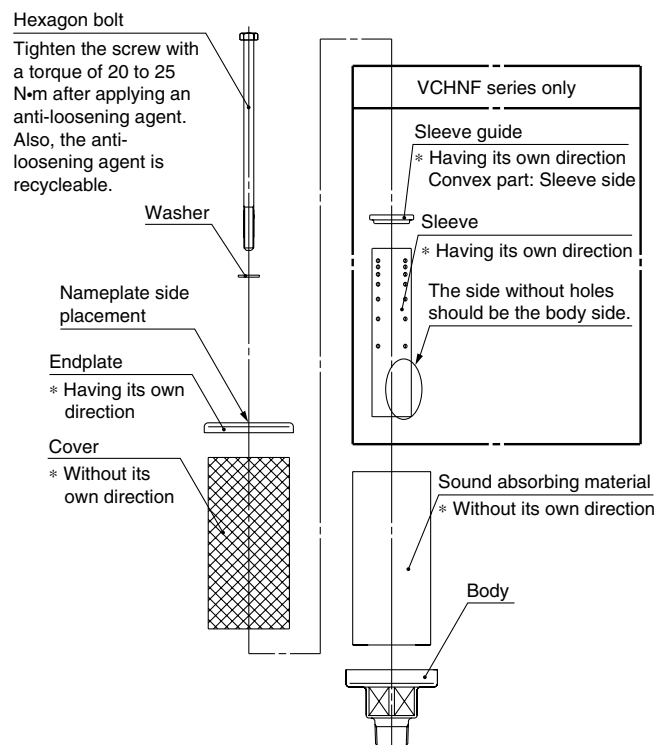

Replacement Parts

Sound Absorbing Material Part No.

Part no.	Description	Applicable model
VCHN3-EL	Sound absorbing material	For VCHN(F)3
VCHN4-EL	Sound absorbing material	For VCHN(F)4

Made to Order

For detailed dimensions, specifications and delivery, please contact us.

1 6.0 MPa piloted regulator (Air operated type)

VCHRA

Remote control is possible with electro-pneumatic regulator ITV.

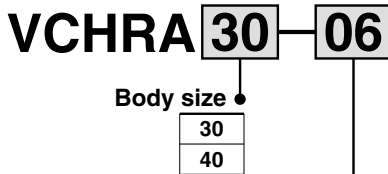

Port size

Symbol	Port size	VCHRA30	VCHRA40
06	3/4	●	
10	1	●	●
14	1½		●

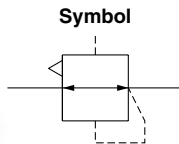

Specifications

Model	VCHRA30	VCHRA40
Valve construction	Piston type	
Valve material	Polyurethane elastomer	
Relief mechanism	Relieving type	
Port size	G3/4, G1	G1, G1½
Port size Thread standard	Conforming to ISO1179-1 on the pneumatic/hydraulic G thread	
Fluid	Air	
Max. operating pressure	6.0 MPa	
Pilot pressure range	Refer to the graph.	
Set pressure range	0.5 to 4.5 MPa	
Fluid temperature	-5 to 60°C	
Ambient temperature	-5 to 60°C	
Weight	2.9 kg	4.1 kg

Pilot pressure range

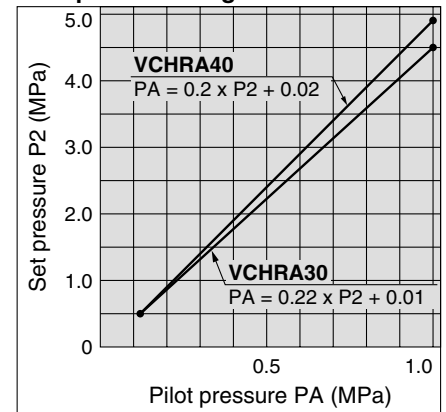

2 22.0 MPa 2 port air operated valve

AXT836 A

Specifications

Symbol	Passage	Piping size
A	N.C.	1/4" fitting integrated type
B	N.O.	1/4" fitting integrated type
C	N.C.	Flange type
D	N.O.	Flange type
E	Double acting	1/4" fitting integrated type



Integrated fitting type Flange type

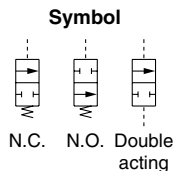

Specifications

	A, C (N.C. type)	B, D (N.O. type)	E (Double acting)
Fluid	Air/Insert gas		
Fluid temperature	-10 to 60°C (with no freezing)		
Ambient temperature	-10 to 60°C (with no freezing)		
Operating pressure range	0 to 22.0 MPa	0 to 20.0 MPa	
Proof pressure	35.0 MPa		
Pilot pressure range	0.45 to 0.7 MPa	0.3 to 0.5 MPa	
Valve leakage	0.1cm ³ /min or less		
Orifice size	2.8 mm		

3 5.0 MPa pressure sensor

Specifications

Model	PSE560-X512
Rated pressure range	0 to 5.0 MPa
Withstand pressure	10.0 MPa



Related Equipment

2-color display digital pressure switch *Series ISE75/75H*

- 10.0 MPa: ISE75
15.0 MPa: ISE75H
- 2-color display
- Metal body (Aluminum die-cast)
- IP67



Specifications

Model	ISE75	ISE75H
Rated pressure range	0 to 10.0 MPa	0 to 15.0 MPa
Set pressure range	0.4 to 10.0 MPa	0.5 to 15.0 MPa
Withstand pressure	30.0 MPa	45.0 MPa
Set pressure resolution	0.1 MPa	
Fluid	Fluids that do not corrode stainless steel 430 and 630	
Power supply voltage	12 to 24 VDC, Ripple (p-p) 10% or less (with power supply polarity protection)	
Current consumption	55 mA or less (at no load)	
Switch output	Output -43: 1 setting; NPN open collector 1 output (Pin no. 4) + PNP open collector 1 output (Pin no. 2) ^{Note 2)} Output -65: PNP open collector 1 output (Pin no. 4)	
Max. load current	80 mA	
Max. applied voltage	30 V (with NPN output)	
Residual voltage	1 V or less (with load current of 80 mA)	
Response time	2.5 ms (Response time selections with anti-chattering function: 20 ms, 160 ms, 640 ms, 1000 ms, 2000 ms)	
Short circuit protection	With short circuit protection	

Note) The NPN and PNP outputs activate with a single set value.



SMC'S GLOBAL MANUFACTURING, DISTRIBUTION AND SERVICE NETWORK

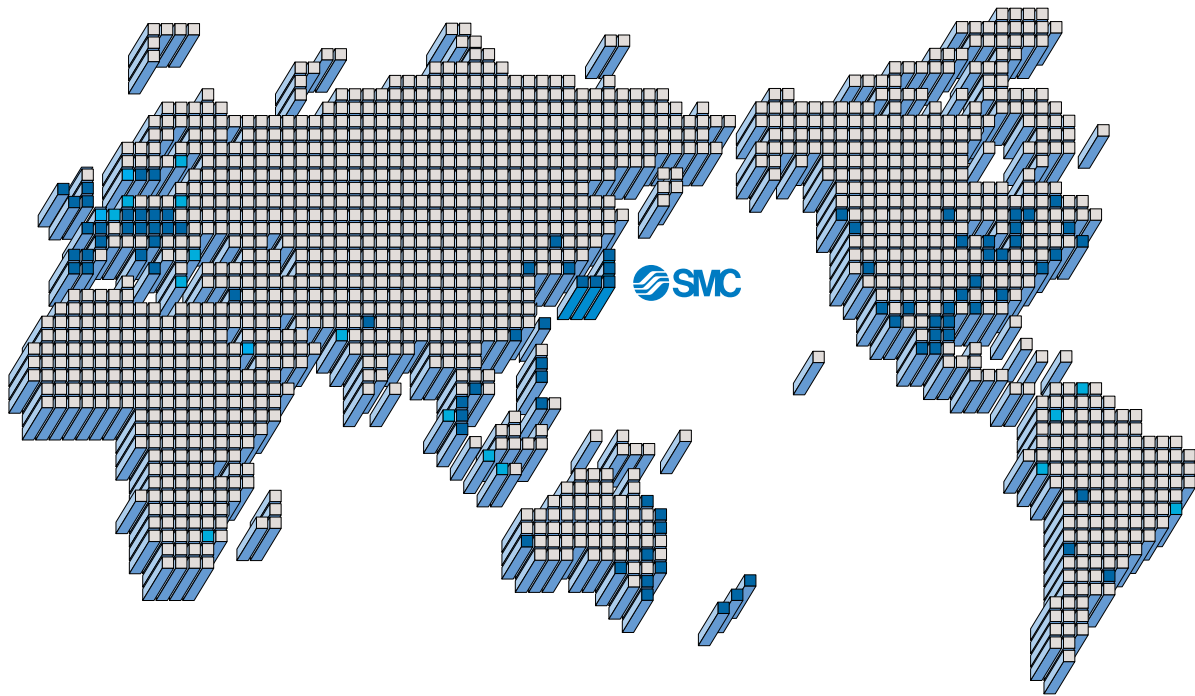

EUROPE

AUSTRIA

SMC Pneumatik GmbH

BELGIUM

SMC Pneumatics N.V./S.A.

BULGARIA

SMC Industrial Automation Bulgaria EOOD

CROATIA

SMC Industrijska automatika d.o.o.

CZECH REPUBLIC

SMC Industrial Automation CZ s.r.o.

DENMARK

SMC Pneumatik A/S

ESTONIA

SMC Pneumatics Estonia OÜ

FINLAND

SMC Pneumatics Finland OY

FRANCE

SMC Pneumatique SA

GERMANY

SMC Pneumatik GmbH

HUNGARY

SMC Hungary Ipari Automatizálási Kft.

IRELAND

SMC Pneumatics (Ireland) Ltd.

ITALY

SMC Italia S.p.A.

LATVIA

SMC Pnuematics Latvia SIA

NETHERLANDS

SMC Pneumatics BV.

NORWAY

SMC Pneumatics Norway A/S

POLAND

SMC Industrial Automation Polska Sp.z.o.o.

ROMANIA

SMC Romania s.r.l.

RUSSIA

SMC Pneumatik LLC.

SLOVAKIA

SMC Priemyselná automatizácia, s.r.o.

SLOVENIA

SMC INDUSTRIJSKA AVTOMATIKA d.o.o.

SPAIN/PORTUGAL

SMC España, S.A.

SWEDEN

SMC Pneumatics Sweden AB

SWITZERLAND

SMC Pneumatik AG.

UK

SMC Pneumatics (U.K.) Ltd.

ASIA

CHINA

SMC (China) Co., Ltd.

HONG KONG

SMC Pneumatics (Hong Kong) Ltd.

INDIA

SMC Pneumatics (India) Pvt. Ltd.

INDONESIA

PT. SMC Pneumatics Indonesia

MALAYSIA

SMC Pneumatics (S.E.A.) Sdn. Bhd.

PHILIPPINES

SHOKETSU-SMC Corporation

SINGAPORE

SMC Pneumatics (S.E.A.) Pte. Ltd.

SOUTH KOREA

SMC Pneumatics Korea Co., Ltd.

TAIWAN

SMC Pneumatics (Taiwan) Co., Ltd.

THAILAND

SMC Thailand Ltd.

NORTH AMERICA

CANADA

SMC Pneumatics (Canada) Ltd.

MEXICO

SMC Corporation (Mexico) S.A. de C.V.

USA

SMC Corporation of America

SOUTH AMERICA

ARGENTINA

SMC Argentina S.A.

BOLIVIA

SMC Pneumatics Bolivia S.R.L.

BRAZIL

SMC Pneumaticos Do Brazil Ltda.

CHILE

SMC Pneumatics (Chile) S.A.

VENEZUELA

SMC Neumatica Venezuela S.A.

OCEANIA

AUSTRALIA

SMC Pneumatics (Australia) Pty. Ltd.

NEW ZEALAND

SMC Pneumatics (N.Z.) Ltd.

SMC Corporation

1-16-4 Shimbashi, Minato-ku, Tokyo 105-8659 JAPAN

Tel: 03-3502-2740 Fax: 03-3508-2480

URL <http://www.smcworld.com>

© 2005 SMC Corporation All Rights Reserved

Specifications are subject to change without prior notice and any obligation on the part of the manufacturer.

D-DN

1st printing JS printing JX 120DN Printed in Japan.

This catalog is printed on recycled paper with concern for the global environment.